

BLAUPUNKT 'PA' Series Plastic Amplifiers



PA275 (2x75 Watt rms), PA2100 (2x100 Watt rms)

2/1 Channel Digital Power Amplifier

Amplificateur de Puissance Numérique à 2/1 Canaux

Amplificador de Potencia Digital de Canal 2/1

2/1 Amplificador Potência de Canal Digital

● BLAUPUNKT®

POWERED BY TRIPATH®



Class 'T' Digital Amplifier Technology

BLAUPUNKT SPECIFICATIONS - PA275 AND PA2100, 2/1 CHANNEL AMPLIFIER

Below is a basic trouble-shooting guide to assist in seeking out and correcting a problem that may occur in the installation process. Although lengthy, this chart cannot address every single problem possible but mainly the ones most common.

PARAMETER/FEATURE	PA275	PA2100
Channels	2/1	2/1
Size (W x H x D)	7.9 x7.5x2.6 inches (200x190x67mm)	7.9 x7.5x2.6 inches (200x190x67mm)
Weight (with housing)	4.6 lbs (2.1 kg)	4.6 lbs (2.1 kg)
Crimping style speaker terminals?	YES	YES
Maximum terminal wire size	14 ga.	14 ga.
Subsonic filter	YES (10 Hz)	YES (10 Hz)
Separate front/rear or left/right gains?	NO	NO
Fuse Type	ATC spade -30A	ATC spade -40A
Speaker short, short to +12V, and short to ground protection?	YES	YES
High, low, and reverse voltage protection?	YES	YES
Power output transistors	MOSFET	MOSFET
Switching power supply transistors	MOSFET	MOSFET
Minimum speaker impedance (non-bridged)	2 ohms	2 ohms
(bridged)	4 ohms	4 ohms
PERFORMANCE DATA		
Rated power output @ 0.1% THD, 13.8V		
2 channels into 4 ohms / 2 ohms	2 x 75 W / 2 x 100 W	2 x 100 W / 2 x 150 W
1 channel into 4 ohms	1 x 200 W	1 x 300 W
Total Harmonic Distortion @ rated full output	0.03% THD	0.03% THD
Rated Signal/Noise ratio (averaged value)		
Measured @ 1 watt / 1 kHz dBA	82	82
Measured @ full rated power (0.1% THD) dBA	>100	>100
Damping factor	>100	>100
Frequency response (full-range mode)	20 - 50,000 Hz	20 - 50,000 Hz
High-pass crossover frequency limits	50 Hz - 250 Hz (variable), 12dB/oct	50 Hz - 250 Hz (variable), 12dB/oct
Low-pass crossover frequency limits	50 Hz - 250 Hz (variable), 12dB/oct	50 Hz - 250 Hz (variable), 12dB/oct
Input impedance	10 kohms	10 kohms
Input signal voltage control range	0.3 - 6.0 vrms	0.3 - 6.0 vrms
Current Draw @ 13.8 VDC (typical values @ X watts / Efficiency %)		
@ full rated power, bridged mode (@ 4 ohms)	28 A (65%)	36 A (65%)
@ full rated power, unbridged (@ 4 ohms)	16 A (78%)	21 A (78%)
@ 33% rated power, unbridged (@ 4 ohms)	6.0 A (60%)	8.0 A (60%)
@ 10% rated power, unbridged (@ 4 ohms)	3.0 A (40%)	4.0 A (40%)
@ idle (@ 4 ohms)	1.2 A	1.5 A
Minimum battery voltage to maintain rated power	12.6 VDC	12.6 VDC
Usable battery voltage	10 - 16 VDC	10 - 16 VDC
Trigger line voltage range	10 - 16 VDC	10 - 16 VDC
Trigger line current draw	@ 20 mA	@ 20 mA
Turn on delay time	@ 2.0 seconds	@ 2.0 seconds
Thermal shutoff temperature (average heat-sink temp)	@ 85° C (185° F)	@ 85° C (185° F)

NOTE: DUE TO ONGOING PRODUCT IMPROVEMENTS, DESIGN AND SPECIFICATIONS ARE SUBJECT TO CHANGE WITHOUT ADVANCED NOTICE TO THE CONSUMER OR RETAILER.

TABLE OF CONTENTS

What is an amplifier?	2
Key features	2
Safety Concerns & installation warnings	3
System planning	4
Installation tools	4
Vehicle wiring	5
Connections & controls	6-7
System configurations 1 & 2	8
System configurations 3 & 4	9
Troubleshooting chart	10
Warranty information	11
Blaupunkt technical support	11
Assembly & Mounting	Back Cover

THANK YOU FOR CHOOSING BLAUPUNKT!

Congratulations! You are now the owner of an exceptional car audio amplifier from the audio enthusiasts at Blaupunkt. Our engineering staff has spent considerable time refining our PA series amplifiers in order to introduce great sound to the consumer at an affordable price. With these products we focus on sonic performance but balanced with rugged design and flexible installation.

Not only do we offer you a great product but also a supportive owners manual. This manual can be used as a teaching guide due to its brief, but informative, explanations of amplifier and system design. We are also very concerned about the end consumer using proper installation techniques for the highest performance possible from their new audio products. MOST important to us are the concerns with safety and the installation process. Since our Blaupunkt retail dealers have the tools and experience for an optimized and safe installation, we always recommend they do the final vehicle integration. But, should you choose to install these products yourself, please take the time to read this manual completely and abide by all precautions.

ENGINEERING BENEFITS OF BLAUPUNKT'S CLASS "T" AMPLIFIERS

Audio amplifiers take power from the car battery and convert it to audio power. Although much of the energy output is sound, a considerable amount of power is lost as heat. Such heat loss must typically be dissipated via large heat sinks, thus creating heavy metal amps with a large footprint.

In the audio world, Class 'D' amps have recently helped reduce this wasted heat, allowing them to use a smaller enclosure, but their poor fidelity limits them to bass reproduction only. In contrast, conventional Class 'AB' amps march on with their high fidelity, but poor efficiencies. Therefore, the need still exists for an amp with high fidelity, but with low heat and a small chassis.

Class 'T', invented and patented by Tripath® Technologies, provides the best of both worlds with high quality sound, yet low heat dissipation. Due to the remarkably low heat generated we can design very small, hide-away boxes but also creatively shape the external housings from plastics or other materials. With heat losses of only 1/3 to 1/4 of an 'AB' design, Tripath opens up a whole new application world for compact, small design, attractive amps. Looks cool, runs cool!

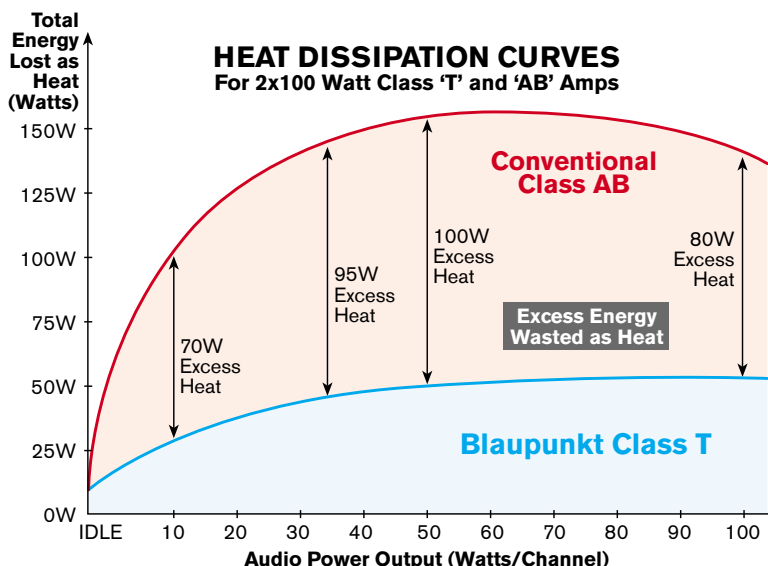

KEY FEATURES

Your new Blaupunkt Amplifier offers some important features:

- "Break-away" design allowing the internal amplifier to be removed from the housing and mounted in a "hide-away" location
- REM1, Remote gain control (operates in bass mode only)
- HLA1, High Level Adapter allowing for speaker level voltage to drive the amplifier
- Plugs that allow for wiring the vehicle first then connect the amp
- Continuously variable high-pass and low-pass crossover filters
- Bass boost control (fixed gain)
- Interchangeable colored plastic control lenses (optional)
- 2 ohm (non-bridged) capability
- 0.3-6.0Vrms input capability allowing for wide range drive voltage capability from a receiver or other media device



SAFETY CONCERNS

We always recommend you have your Blaupunkt amplifiers professionally installed but the installation process is often so easy that the average consumer can achieve success with little trouble. Regardless of the person installing, you should be sure to review the following points before proceeding with the installation:

- **READ THE MANUAL!** Understanding the product and installation limitations before lifting a screwdriver.
- **WEAR SAFETY GLASSES AT ALL TIMES** - Flying debris are always dangerous.
- **PROTECT THE VEHICLE** - Always disconnect the negative battery cable before starting any kind of installation work. This prevents a possible high current electrical short (potential fires).
- **HEAT** - Keep all audio components away from nearby hot vehicle components that heat up over time such as hoses, high current wires, and braking system components.
- **GIVE YOURSELF LOTS OF TIME** - Rushing to complete an installation nearly always ends up with problems.
- **DO NOT LISTEN AT HIGH SOUND LEVELS FOR A PROLONGED TIME** - these amplifiers, used with high efficiency speakers from ANY manufacturer, have the potential to cause permanent hearing loss after listening at maximum volume levels for several hours.



INSTALLATION WARNINGS!

Before disassembling your beautiful new car you need some basic installation knowledge and skill with common hand and power tools. Following such basic installation tips and warnings will prevent possible damage to the vehicle and also prevent possible fires.

- **AGAIN...READ THE MANUAL!** There is a lot of helpful information in this manual that will save time and prevent problems later.
- **COVER THE VEHICLE WORK AREAS** - Use fender covers or blankets to protect the work areas from scratches or dings.
- **DISCONNECT THE (-) LEAD ON THE BATTERY** - No sparks or fires please!
- **“REVIEW” THE INSTALLATION** - Before using any tools or moving vehicle components, take five minutes to review the installation intentions (e.g., verify that an amplifier will fit in an area of a car before tearing out all the interior).
- **“REVIEW” THE VEHICLE** - Before drilling any holes or cutting into any surfaces, make sure there are no fuel or hydraulic lines behind the surfaces. Also make sure there are no wires routed directly behind or near the desired mounting area (remember...screws can often extend 1-2 inches behind the mounting surface).
- **ENSURE PROPER FIT** - Before cutting or drilling, make sure the amplifier will physically fit in its desired location. Check for clearance around rear deck torsion bars or other structural elements.
- **EVERY CAR IS ASSEMBLED DIFFERENT** - Every auto manufacturer uses different assembly techniques. Take care in removing/modifying all trim panels and mounting surfaces since they often use unique screws or snap fasteners that are difficult to replace if they are lost or broken.
- **BE CAREFUL WITH CABLE ROUTING** - When routing audio cables, make sure RCA and speaker wires are routed away from high current power lines for audio amplifiers and vehicle systems lines when possible. This will help prevent noises from creeping into the audio system, plus prevent potential damage to the vehicle wiring itself.
- **BE CAREFUL WITH ALL CONNECTIONS** - When making connections, make sure each connection is clean and properly secured. Observe all polarity markings carefully to ensure proper end performance.
- **CAUTION - FUEL TANKS AND FUEL LINES ARE NOW LOCATED DIRECTLY BENEATH THE REAR DECK IN MANY CARS - CHECK FOR ADEQUATE CLEARANCE BEFORE EVEN CONSIDERING SUCH A MOUNTING LOCATION!**

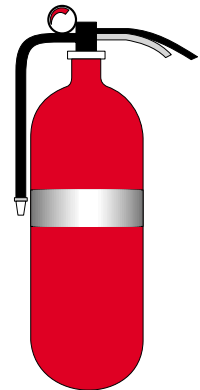

SYSTEM PLANNING

Before wiring up an audio system that may not achieve the sound quality you want, be sure to choose a system concept that fits your listening requirements. Basic systems, a receiver with internal 4x20 watts and 4 coax speakers, are adequate for many listeners. But, when you want to really “feel” the music, you will need some kind of subwoofer amplifier/speaker combination. Although many people might jump into an “add-on” amplifier to power to rear coaxial speakers, a better choice is usually a subwoofer amp/speaker system that supplements the existing 4 speaker system as shown in the adjacent drawing. Such a system provides a surprising improvement in sound quality due to the usually dramatic increase in bass response.

The next dramatic step up in performance is with a “multi-channel” system that offers more dynamic range in the mids and highs due to higher power plus more bass response due to multiple woofers and/or more power. But, with such a system, the stereo image and overall listening experience usually becomes much more life-like due to better tonal quality midrange/tweeter speakers and usually better placement.

To build such a system though, complexity goes up due to the addition of passive or active crossovers which take time to install and may inject noise into the system due to potential noise signal pick up. The results though of such a system can be dramatically pleasing.

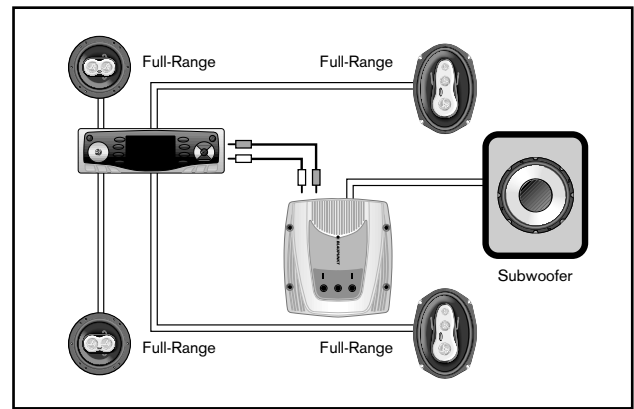

Supplementary subwoofer system

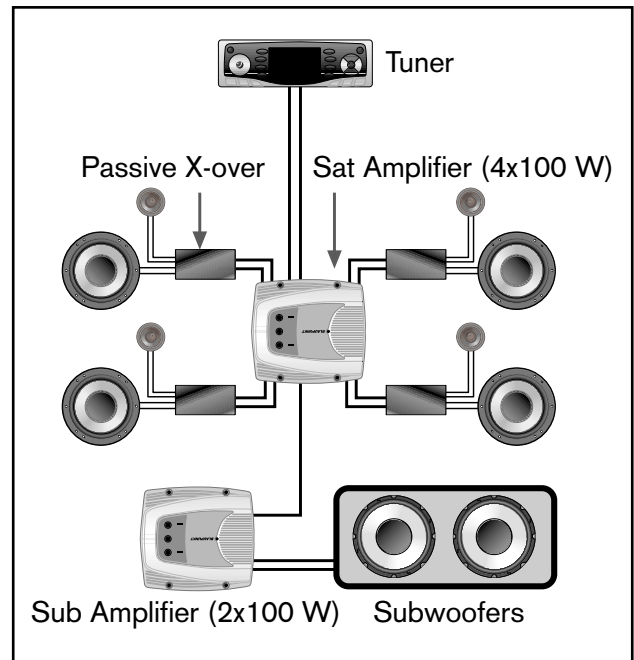

High performance multi-channel system

INSTALLATION TOOLS

For most installations, simple hand tools are adequate to install an aftermarket amplifier. Depending upon the mounting locations used, you will need power tools for drilling and cutting plastics and metal. A good starting list is summarized below:

- Tape measure and ruler
- Marking pen and starting punch
- Phillips and flat blade screwdrivers (small and medium sizes)
- Nylon wire bundle ties
- Pliers: standard vice-grip and needle nose styles
- Light-duty trim pry-bar for removing door trim
- Cutting shears or nibbling tool for cutting thin and medium gauger metal
- Wire cutters, wire strippers, electrical tape, crimping pliers and appropriate crimp-on terminals
- Power drill with appropriate sized drill bits

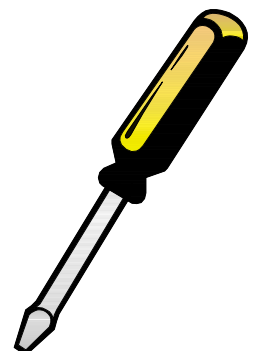

VEHICLE WIRING

VEHICLE FUSING

For safety purposes, a high current fuse (or circuit breaker) **MUST** be installed in line with the amplifiers(s) immediately at the battery to prevent vehicle damage should the battery line in advertently shorted to the vehicle chassis. The chart at the right shows the recommended master fuse sizes for an average audio system with noted "rms" output power levels.

SYSTEM FUSE CHART (Fuse size for total amplifier system power in "rms" watts)				
	100 W	200 W	500 W	1000 W
Fuse Size (in amps)	20 A	30 A	50 A	100 A

POWER WIRING

Most vehicles built since 1990 have adequate current capability for your amplifier. Except for systems above about 500 W rms, the factory charging system and battery should easily support it if properly installed. Proper wire size must be chosen to ensure adequate current delivery to the amp. Wire size (gauge) of the cables need to increase in size for higher power systems. (Wire sizes larger than those noted are usually a waste of time and money since they offer little or no performance improvements.)

Wire diameter must increase (decreased wire gauge number) for higher power systems. For long wire runs the wire diameter must also increase. The wire sizes noted allow for a maximum 0.5 volts DC drop over the give wire run which results in Sound Pressure Level drops inaudible to the average listener.

SYSTEM POWER AND GROUND WIRE CHART (Wire gauge for total system in 'rms' watts)				
WIRE LENGTH	100 W	200 W	500 W	1000 W
5 ft. / 1.5 m	12	10	8	4
10 ft. / 3.0 m	12	10	8	4
15 ft. / 4.5 m	10	8	6	2
20 ft. / 6.0 m	10	8	6	2
25 ft. / 7.5 m	10	8	4	0 or 00

SPEAKER WIRING

As with power wire, speaker wire size (gauge) changes with the power required and the length of the wire run. The speaker wire chart shows the minimum recommended wire size for a single audio output channel driving a loudspeaker at a given distance with a maximum power loss of 0.5 dB, the threshold of audibility. (Wire sizes larger than those noted are usually a waste of time and money since they offer little or no performance improvements.)

LOUDSPEAKER WIRE CHART (Wire gauge per loudspeaker/speaker power in "rms" watts)				
WIRE LENGTH	20 W	50 W	100 W	200 W
5 ft. / 1.5 m	18	16	16	16
10 ft. / 3.0 m	18	16	16	16
15 ft. / 4.5 m	16	16	16	14
20 ft. / 6.0 m	16	16	16	14
25 ft. / 7.5 m	16	16	14	12

FINAL VEHICLE WIRING

Current requirements for an upgraded audio system dictate a dedicated power line be run from the amplifier directly to the battery of the vehicle. This line should **NOT** be run to the fuse panel of the vehicle but directly to the battery. **DO NOT** run to the alternator either. There **MUST** be a fuse installed at the battery with adequate amperage as shown in the chart above.

As for the final signal wiring, be sure to route the audio cables down the side of the car opposite the power lines to avoid noise pick up from the lines. Also, try to route all audio cables away from noise sources such as engine computers and ABS brake computers.

Proper power grounding is important to insure adequate current flow. Be sure to grind the surface clean of all paint to ensure a solid electrical connection.

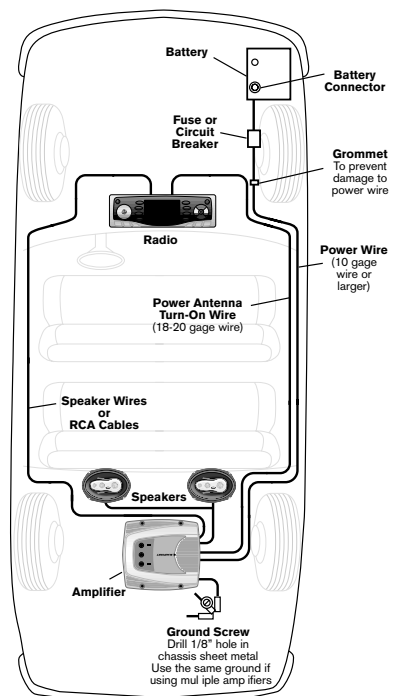

CONNECTIONS & CONTROLS

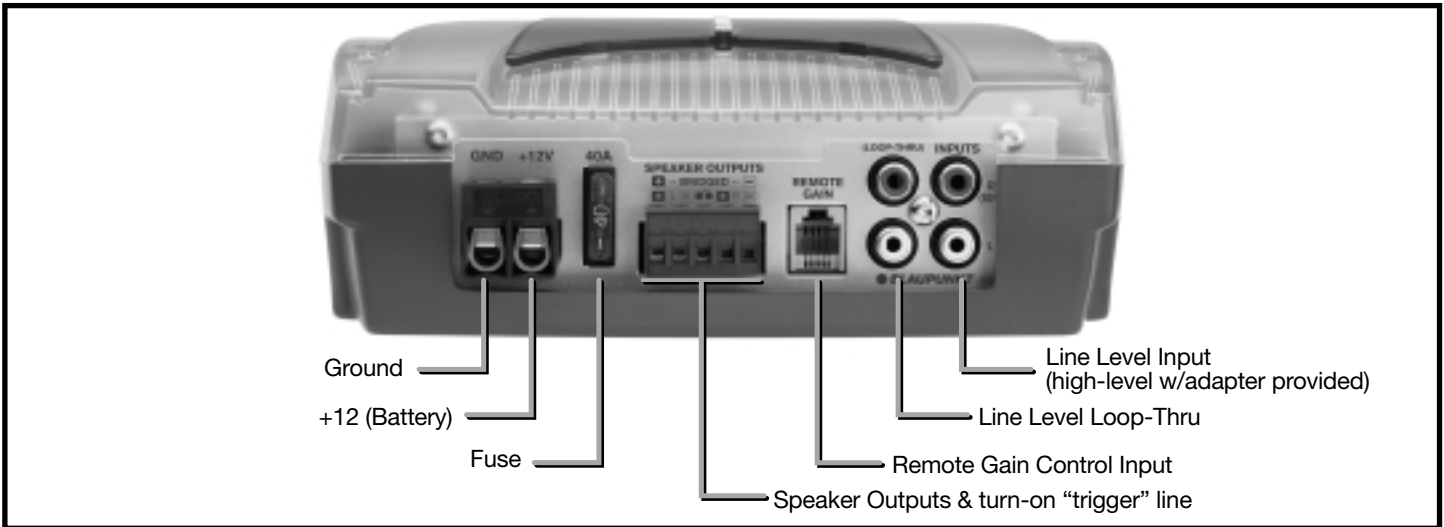

POWER CONNECTIONS:

GROUND - This is the high current ground connection to the chassis of the car. It should be fastened to a clean ground connection in the vehicle, capable of handling high current loads. This wire should be no longer than 3 feet (1 meter)

+12v - A high current line run direct from the batter is highly recommended to insure adequate current and voltage. This line **MUST** be run through a dedicated fuse of some kind and this fuse should be located immediately next to the power source. This in-line fuse is used to protect the vehicle should a short to chassis occur.

TRIGGER - This line tells the amp to turn on and is remotely switched from the radio which normally provides an amp "trigger" output. This line is required to go "high" (+12V) to turn on the amp. If this line is not available, use the power antenna line trigger which is normally available in most radios.

FUSE - This fuse is only for catastrophic situations should the amplifier begin to self-destruct or incur installation situations where gross amounts of current are being required from the amp beyond its design limits. Although another fuse should be installed inline with the high power line at the battery, this amplifier mounted fuse **MUST** remain in the circuit to protect the amplifier.

SPEAKER OUTPUTS - The amplifier is connected to appropriate impedance speakers via these leads. It is **IMPERATIVE** that these leads **NOT** be connected or touch the vehicle chassis in any way or the amplifier will be damaged. The (+) and (-) leads of the amp are in no way inter-connected to one another. Also, **NONE** of the leads can touch each other, touch ground, or touch +12V or damage may occur to the amp or vehicle.

REMOTE GAIN CONTROL - This amplifier is provided with internal circuitry that allows for a remote gain control to adjust the bass output level depending upon the listener's choice. **ONLY** the supplied gain control can be used with the amp or the circuitry for it to be used properly.

CAUTION!! Unfortunately you **CANNOT** use simple telephone "Y" connectors to daisy chain to multiple amps in hopes of controlling the gains of multiple amps.

LINE LEVEL INPUTS - The most commonly used inputs in the aftermarket world are RCA type line level inputs. These inputs can handle up to about 6 Volts rms without overdriving the amplifier. Such high voltages are rarely found from car audio head units so this is a very comfortable value. But, should the use need to drive the amp directly from speaker level leads, use the supplied "High Level Adapter" to connect to the amp.

LINE LEVEL LOOP-THRU - These connectors are simply hard wired to the other inputs and do not loop-through the crossovers in any way. If you wish to "daisy-chain" multiple amps simply connect them to the "loop-thru" leads.

Power Terminal (+12V)

Connect directly to the vehicle battery (+) terminal with 10 gage wire (minimum)

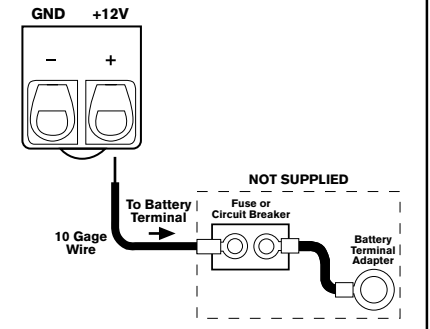

Ground Terminal

Connect to a good chassis ground. The ground connection should be clean, unpainted metal to provide a good electrical connection.

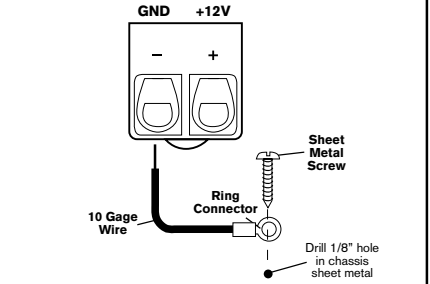

Remote Terminal

Connect the radio power antenna lead from the receiver to the amplifier remote terminal. This turns the amplifier on whenever the receiver is turned on.

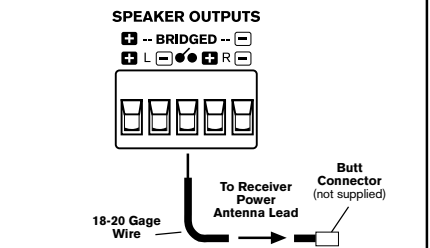

CONNECTIONS & CONTROLS

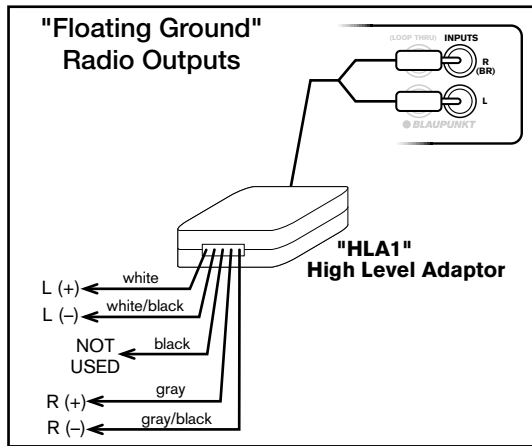
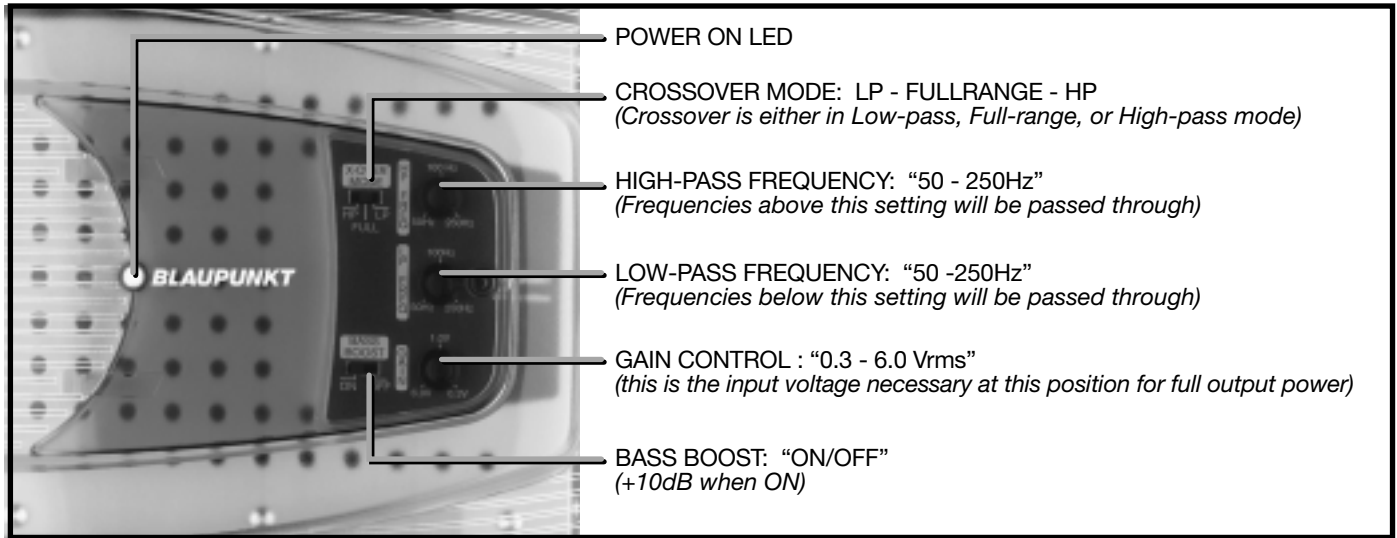

POWER ON LED - This light will turn on when the amplifier receives a +12V turn on signal from the radio. If the amp is properly wired, but the light does not turn on, there may be a short circuit condition that the amp is protecting itself from.

BASS BOOST - This control provides additional bass in the 45Hz area to give a stronger low end "feel" to the bass. Once switched on, this will also allow the amp to be driven into distortion sooner so the user must be aware.

GAIN CONTROL - The gain control allows for a range of 0.3-6Volts input. This means that if the setting is a 0.3V, it only takes 0.3Volts to drive the amp to full output. (Such a low setting allows for the amp to be easily overdriven and more susceptible to noise so a mid-position is highly recommended for most radios.)

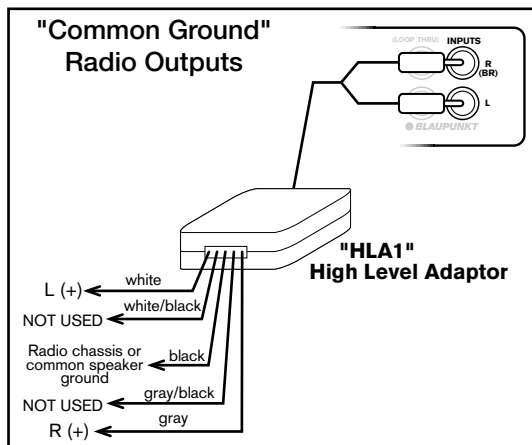

LOW-PASS FREQUENCY - If the mode selector is in the "LP" position the amplifier passes only low frequency sound. The upper limit for such sound is set via this control. For bass, a value just below 100Hz is usually best.

HIGH-PASS FREQUENCY - If the mode selector is in the "HP" position the amplifier passes only mid and high frequency sound. The lower limit for such sound is set via this control. A common setting is just above 100Hz.

CROSSOVER MODE - Depending upon the system design chosen, you need to set the amplifier in the proper "mode" be it LP, Fullrange, or HP. The low-pass and high-pass frequency settings are explained above. The "full-range" setting simply allows for the amp to pass all audio frequencies without any kind of crossover filter application. (This is common with 6x9" fullrange coaxial speakers for example.)

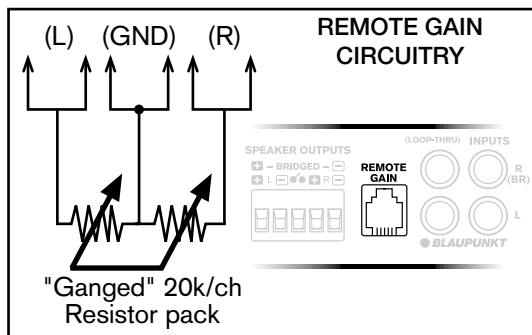

REMOTE GAIN CIRCUITRY

Should the installer wish to create their own remote gain control, or attempt to daisy chain the gains of multiple amps, refer to the adjacent circuit design for proper connection. This should **ONLY** be attempted by a very highly qualified installation technician. If improperly done **DAMAGE WILL OCCUR** to the amplifier and **WILL NOT** be covered by warranty! (We put this information in this manual because of the interest of our highly skilled Blaupunkt installers - the average consumer should **NOT** attempt this on their own!)

You should **ONLY** loop the **SIGNAL** pin to other amps - **DO NOT** carry the ground and +12V pin voltages to adjacent amps.

SYSTEM CONFIGURATION #1

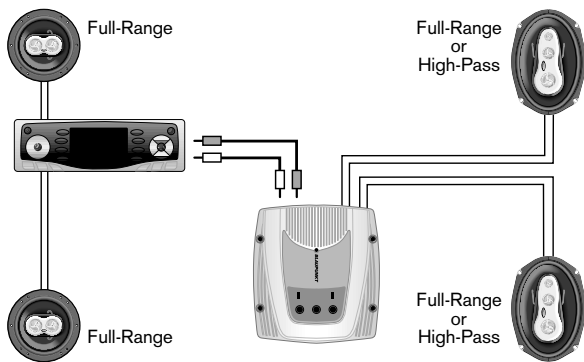

2 Channel Full-range -or- High-Pass Mode

This installation is most popular for listeners who want to simply increase the power to the rear speakers in a car. The resulting performance is most commonly a louder overall sound field from the rear.

But, such a system's biggest benefit is the additional bass response since the bass control of the radio can be turned up without distorting the amplifier. Such a system is not necessarily louder in the mids and highs but is able to play louder in the low frequencies due to this additional power. This leads to an overall richer and stronger sound experience for the listener without additional subwoofer boxes or electronics that may complicate the system or take up more room. Such a system WILL NOT equal the performance of a subwoofer system but will certainly be a pleasant improvement.

With the addition of a high-pass filter, this amplifier is set up to complement a dedicated subwoofer amplifier/speaker system. This allows for smaller (e.g., 5" or 6") satellite speakers to operate most efficiently without being over-driven in the bass region where a dedicated subwoofer system operates most efficiently.

Connect Speakers as shown. For best sound, always make sure to connect + to + and - to -

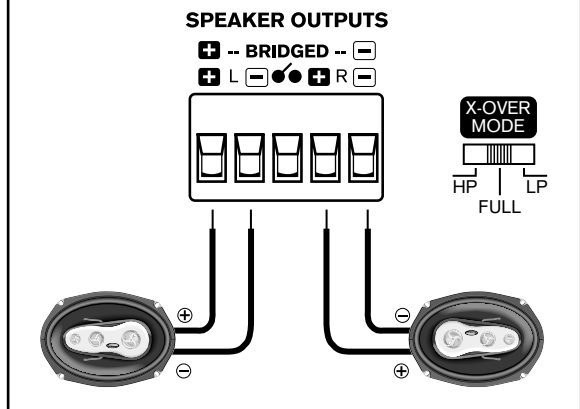

SYSTEM CONFIGURATION #2

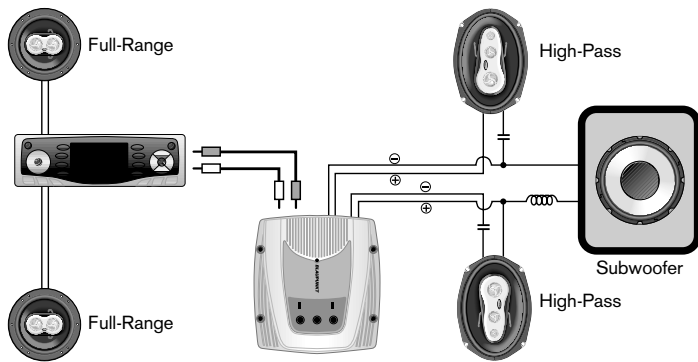

3 Channel Multi-Mode (Passive)

The multi-mode system is a "poor-man's" satellite/subwoofer system. This amplifier is able to drive speakers in stereo mode and at the same time drive low frequencies to a dedicated subwoofer speaker. By inserting inductors (coils) and capacitors, the result is an inexpensive solution to generating a '3' channel system with a 2 channel amplifier.

Using passive components (coils and capacitors) the installation is simple and performs adequately for most listeners. Such a system will not perform as well as an "active" system because the slow attenuation (roll-off) of the frequency response resulting in a moderate amount of over-lapping of the sound spectrum between the satellites and subwoofers. It is important to remember that although surprisingly pleasant performance is achieved, this is a compromise system and will NOT perform as well as a dedicated 3 channel system with electronic crossovers.

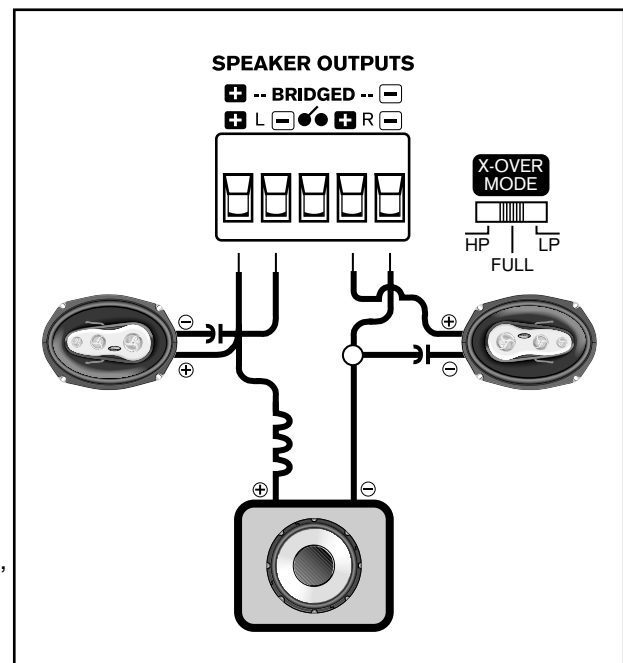

SYSTEM CONFIGURATION #3

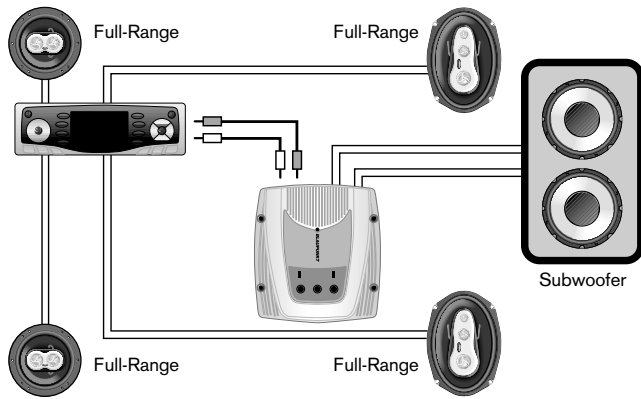

2 Channel Dual Subwoofer Mode

The largest improvement in sound quality always comes when adding some kind of subwoofer via a dedicated subwoofer amplifier and electronics crossover. The electronic crossover ensures minimal overlap of the bass response with the mid and high frequencies from the other speakers resulting in a more accurate performance compared to conventional coaxials with additional power.

By installing this amplifier in the stereo mode, you are able to drive two subwoofer speakers and in to low impedance loads (e.g., 2 ohms) without over heating the amplifiers. Also, such an installation more easily supports a standard 2 speaker woofer box that may already be constructed. Since two woofers can play 6 decibels louder than one at a given power (due to acoustical laws of “mutual-coupling”), the resulting sound pressure level is substantial. This is probably the most common use for a conventional two channel amplifier there is.

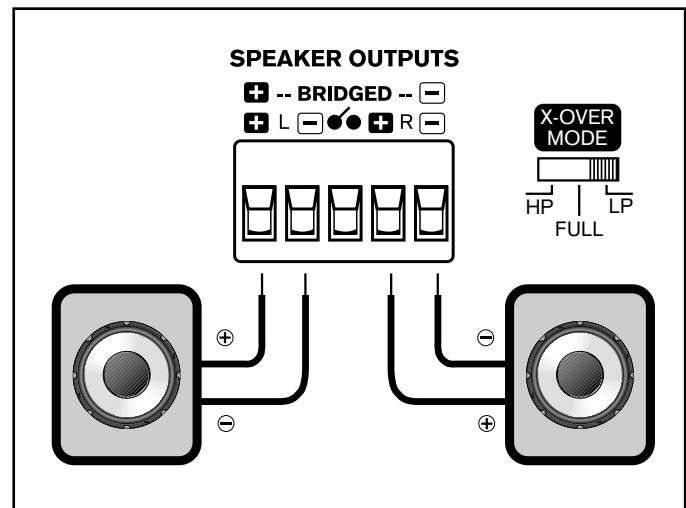

SYSTEM CONFIGURATION #4

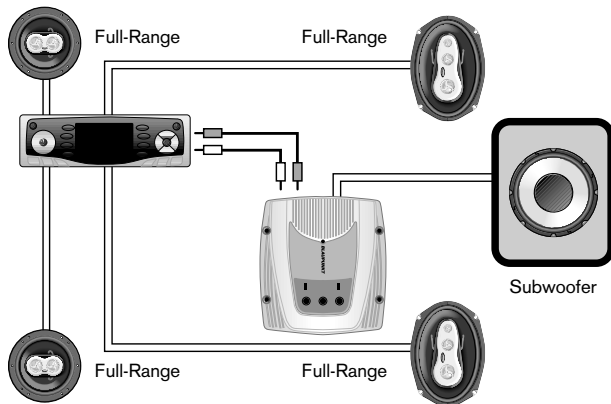

1 Channel Bridged Subwoofer Mode

By electrically connecting a subwoofer speaker in the way shown above, you are able to greatly increase the output power delivered from the amplifier to the speaker. Such a circuit increases the voltage “swing” across the speaker which increase the power seen by a factor of 2 to 4 times that in stereo mode.

This is a very logical set-up for systems that are space limited to allow for only one subwoofer in a vehicle. The number and box volumes are compensated by simply more amplifier power pushing a single speaker.

Such a configuration is also a surprisingly good performer. These increases in power are always welcome but you must take care to avoid low impedances (below 4 ohms) since most amplifiers will overheat and shut down if over-driven into such a configuration. You must also take care that you are not exceeding the thermal, or excursion, power limiting values for the woofer. Surprisingly high power levels can be achieved with such a system without realizing it thus quickly damaging the woofer.

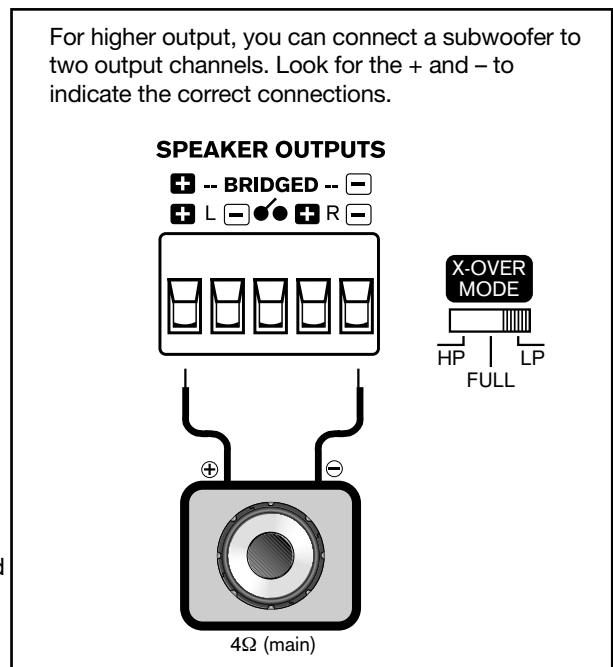

For higher output, you can connect a subwoofer to two output channels. Look for the + and - to indicate the correct connections.

TROUBLE-SHOOTING GUIDE

Below is a basic trouble-shooting guide to assist in seeking out and correcting a problem that may occur in the installation process. Although lengthy, this chart cannot address every single problem possible but mainly the ones most common.

SYMPTOM	PROBABLE CAUSE OR CORRECTION
No power (power light not on)	<ul style="list-style-type: none"> ■ Check connections to amps +12 volt, ground, and remote lines. ■ Use voltmeter to verify voltages are at terminals of amp. ■ Check main power connection at battery. ■ Check fuse in power line at battery. ■ Disconnect all speakers but not power lines - if unit then turns on, a speaker short or speaker line touching vehicle chassis is likely.
Power but no sound (power light is on)	<ul style="list-style-type: none"> ■ Check all input cable lines for connection. ■ Disconnect speakers from amp, test speaker lines with digital voltmeter to verify >2 ohms per channel (non-bridged mode).
No sound from one channel or entire side	<ul style="list-style-type: none"> ■ Check radio's balance and fader control positions - verify they are at center. ■ Check speaker connections at amp and speaker. ■ Check input leads for connection to amp.
Very low sound level	<ul style="list-style-type: none"> ■ Verify radio balance and fader controls are at center positions. ■ Check amplifier's input gain control setting - adjust for higher output levels if necessary (gain settings closer to 0.3 volts). ■ Receiver may have very low output voltage levels - a step up "line driver" may have to be used.
Power amplifier turns on and off repeatedly (motor-boating sound)	<ul style="list-style-type: none"> ■ Make sure power connections at batter are tight. ■ Verify battery voltage is >11.5 volts DC (12.5-15V engine on) at amplifier with engine off. ■ Check all radio and amplifier ground connections.
Amplifier turns off during loud or distorted passages	<ul style="list-style-type: none"> ■ Input stage being over-driven - lower input gain (closer to 4 volt setting). ■ Verify battery voltage is >11.5 volts DC at amplifier with engine off. ■ Check all radio and amplifier ground connections. ■ Verify speaker loads >2 ohms on all channels (non-bridged mode).
Amplifier performs fine but gets very hot to the touch	<ul style="list-style-type: none"> ■ Input gain control too high - lower accordingly (closer to 4.0 volt setting). ■ Verify speaker loads >2 ohms on all channels (non-bridged mode). ■ Verify the mounting location allows for free air movement around the amp. Preferably, the amp should be mounted with fins up and down so rising heat moves quickly away from amp.
Amplifier turn-on/turn-off pops or noises	<ul style="list-style-type: none"> ■ "turn on race" - disconnect trigger from radio and turn on/off via a wire jumper to power terminal. If noise goes away, the radio is turning on/off too slowly. This is radio problem and can only be corrected with outboard turn-on delay relay system. ■ Radio "thump" - disconnect the RCA input lines to the amp and turn on/off via radio trigger. If noise goes away without RCA lines connected, the radio is sending pops out through RCA lines. This is a radio problem and can only be corrected with outboard turn-on delay relay system.
Cracking noises on AM/FM radio but not on tape or cd.	<ul style="list-style-type: none"> ■ Ensure the problem is "radiated noise" by placing a portable FM radio near the car engine. If noise is picked up, then it is a vehicle problem and not your system. Research to isolate the source and properly shield or bypass. ■ Are spark plugs and wires > 3 years old? These can often radiate substantial noise when old. ■ Verify the engine block has a good ground connection to chassis ground. ■ Verify the engine compartment hood is grounded to vehicle chassis via a braided grounding strap.
Whining noise, engine running, varies in pitch or loudness with engine speed, AND varies with radio volume control setting (<i>this is generally a RADIO installation problem</i>)	<ul style="list-style-type: none"> ■ Verify all power and ground connections are clean at radio. ■ Re-route radio power and ground so they are sourced from same connections back at amplifier (this is called a "common" ground). ■ Check all ground connections to ensure clean surfaces that have all paint removed and also not oxidation buildup over time. ■ Verify there is some kind of power filtering choke assembly at back of radio. If not, install one.
Whining noise, engine running, varies in pitch or loudness with engine speed, BUT, DOES NOT vary with radio volume control setting (<i>this is generally an amplifier installation problem</i>)	<ul style="list-style-type: none"> ■ Check battery ground connections at chassis are clean and tight, scraped free of oxidation, paint, and grease. ■ Re-route radio power and ground so they are sourced from same connections back at amplifier (this is called a "common" ground). ■ Bypass all equipment between radio and amp (e.g., equalizers) directly connecting radio. If noise goes away, signal processor has problem. ■ Check for signal level "ground loops" - disconnect the outer shield of the RCA cable at one end of the cable (e.g., radio end). If noise goes away, modify cables accordingly. There are voltage differences at the ground connections of the components and these are NOT correctable any other way than such shield cutting or an outboard "ground loop isolator" which is a small transformer.

LIMITED WARRANTY INFORMATION (UNITED STATES ONLY)

Robert Bosch Corporation warrants new Blaupunkt car audio products it distributes in the United States through authorized Blaupunkt dealers, or which are imported as original vehicle equipment by the automobile manufacturer, to be free from defects in material and workmanship, in accordance with the following:

For twelve (12) months after delivery to you, the original consumer purchaser, we will repair or at our option replace at no charge to you any car audio product which, under normal conditions of use and service, proves to be defective in materials or workmanship. However, this warranty does not cover expenses incurred in the removal or reinstallation of any car audio product, whether or not proven defective, and does not cover products not purchased from an authorized Blaupunkt dealer. This warranty is limited to the original consumer purchaser and is not transferable. Repaired and replacement car audio products shall assume the identity of the original for purpose of this warranty and this warranty shall not be extended with respect to such products.

To obtain performance of this warranty, contact the nearest Blaupunkt authorized repair facility or our nearest office. A dated purchase receipt or other proof that the product is within the warranty period will be required in order to honor your claim. Carefully pack the unit and ship prepaid to the servicing location. For further information, write to the Robert Bosch Corporation, 2800 South 25th Avenue, Broadview, Illinois, 60153, attention Blaupunkt Customer Service Department or call 1-800-266-2528.

Specifically excluded from this warranty are failures caused by misuse, neglect, abuse, improper operation or installation, dropping or damaging, unauthorized service or parts, or failure to follow maintenance instructions or perform normal maintenance activities. Normal maintenance activities for car audio products include but are not limited to cleaning and other minor maintenance activities and adjustments that are outlined in the owner's manual or that are normally required for continued proper operation. Also excluded from this warranty is the correction of improper installation and the elimination of any external electromagnetic interference. This warranty sets forth your exclusive remedies with respect to the products covered by it. We shall not be liable for any incidental, consequential, special or punitive damages arising from the sale or use of any Blaupunkt car audio products, whether such claim is in contract or tort. No attempt to alter, modify, or amend this warranty shall be effective unless authorized in writing by an officer of Robert Bosch Corporation.

THIS WARRANTY IS IN LIEU OF ALL OTHER WARRANTIES OR REPRESENTATIONS, EXPRESS OR IMPLIED, INCLUDING ANY WARRANTY IMPLIED BY LAW, WHETHER FOR MERCHANTABILITY OR FITNESS FOR A PARTICULAR PURPOSE OR OTHERWISE AND SHALL BE EFFECTIVE ONLY FOR THE PERIOD THAT THIS EXPRESS WARRANTY IS EFFECTIVE.

In the event any provision, or any part or portion of this warranty shall be held invalid, void or otherwise unenforceable, such holding shall not affect the remaining part or portions of that provision or any other provision hereof.

NOTICE TO CALIFORNIA OWNERS: If your Blaupunkt car audio product needs warranty repair service and there is no authorized service center reasonably close to you, you can return the defective unit to the dealer from whom you purchased it, or you can return it to any dealer who sells Blaupunkt car audio products. The dealer may, at the dealer's option, replace, repair or refund the purchase price for any Blaupunkt car audio products which prove defective under conditions of normal use. If the dealer fails to repair, replace, or partially refund your money, you may take your Blaupunkt car audio product to any repair shop and they can repair your unit at our expense unless the repair cost exceeds the depreciated value of the unit, but you must contact Blaupunkt to receive authorization to do this before your car audio product is repaired.

ROBERT BOSCH CORPORATION
BLAUPUNKT CUSTOMER SERVICE
2800 SOUTH 25TH AVENUE
BROADVIEW, IL 60155
TEL: 1-800-266-2528

BLAUPUNKT TECHNICAL SUPPORT

These amplifiers are designed to install quickly and easily into most vehicles. Should you experience installation problems, we will make all reasonable efforts to help you, the end purchaser or Installation Technician, to competently install these components. Before calling us please carefully review this owners manual for the answers to your questions.

Due to the limited print space of this owners manual, we also offer additional information regarding installation and systems on our Internet site. Via a standard Internet connection through a local Internet Service Provider or other providers (e.g., America Online), connect to our web site at the following address: www.BlaupunktUSA.com. On this site we offer technical information on system design, vehicle integration, product fit guides where possible, and extensive information on loudspeaker design and installation. For the more adventuresome builder, we also offer our "BlauBox" computer program which assists in designing subwoofer enclosures. This program is FREE to download and use. We also "link out" to other sites that provide additional theory and technical support for the consumer and the technically interested.



MERCI D'AVOIR CHOISI BLAUPUNKT!

Félicitations ! Vous êtes maintenant propriétaire d'un amplificateur pour autoradio exceptionnel, produit par les audiophiles enthousiastes de Blaupunkt. Notre équipe d'ingénieurs a passé un temps considérable à raffiner notre ligne d'amplificateurs PA, afin de vous apporter un son remarquable à un prix abordable. Nous nous concentrons avec ces produits sur la performance sonore, allée à une conception solide et à une installation flexible.

Nous vous offrons non seulement un produit remarquable, mais également un manuel du propriétaire pratique. Ce manuel peut être utilisé comme un guide d'apprentissage, grâce à ses explications brèves mais informatives sur la conception des systèmes et des amplificateurs. Nous voulons également nous assurer que le consommateur utilisera des techniques d'installation appropriées afin de tirer la meilleure performance possible de leur nouveau matériel audio. Nos préoccupations MAJEURES sont la sécurité et le processus d'installation. Nos revendeurs Blaupunkt ayant les outils et l'expérience nécessaires à une installation sûre et optimale, nous recommandons toujours qu'ils se chargent de l'intégration finale au véhicule. Toutefois, si vous décidez d'installer ces produits vous-même, veuillez prendre le temps de lire ce manuel jusqu'au bout et d'en observer toutes les précautions.

AVANTAGES TECHNIQUES DES AMPLIFICATEURS DE CLASSE T DE BLAUPUNKT

Les amplificateurs audio reçoivent leur alimentation des batteries de voiture et la convertissent en puissance audio. Bien qu'une grande partie de l'énergie de sortie soit sonore, une puissance considérable est perdue sous forme de chaleur. Cette perte calorifique doit généralement être dissipée au moyen de dissipateurs thermiques de grandes dimensions, ce qui crée des amplis lourds en métal occupant une place importante.

Dans le monde audio, les amplis de Classe "D" ont aidé récemment à réduire cette énergie gaspillée, ce qui leur permet d'utiliser une enceinte plus petite, mais leur fidélité médiocre les limite à ne reproduire que les graves. Par contre, les amplis "AB" classiques défilent avec leur fidélité élevée, mais cela au prix de rendements médiocres. Par conséquent, le besoin existe encore d'avoir un ampli qui ait une fidélité élevée, tout en émettant peu de chaleur et se logeant dans un châssis de petites dimensions.

La Classe "T" inventée et brevetée par Tripath Technologies procure ce qu'il y a de mieux dans les deux mondes en ayant un son de haute qualité tout en dissipant peu de chaleur. Par suite de la chaleur créée remarquablement faible, nous pouvons concevoir de très petites boîtes qui se cachent, mais nous pouvons aussi donner de façon créative aux logements des formes en plastique ou en d'autres matériaux. Avec des pertes thermiques qui sont seulement entre 1/3 et _ de celles d'une conception "AB", Tripath ouvre tout un monde nouveau d'applications à des amplis compacts, petits et séduisants. Ayez l'air froid, fonctionnez de manière froide !

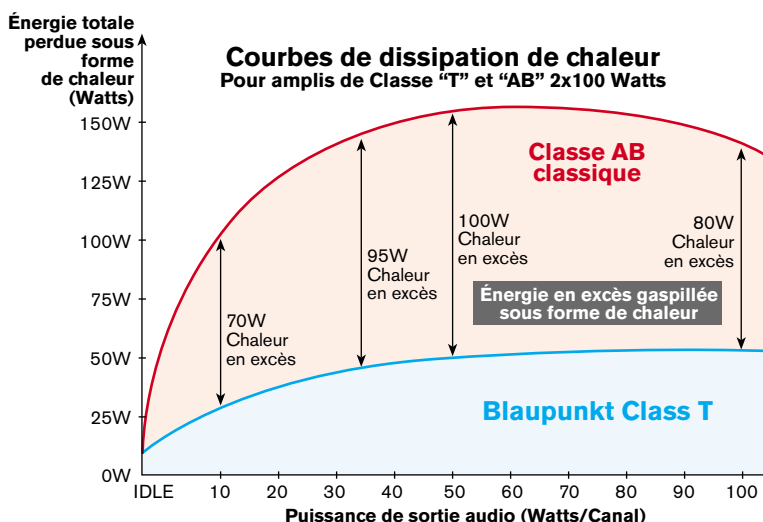

CARACTÉRISTIQUES PRINCIPALES

Votre nouvel amplificateur Blaupunkt offre des particularités importantes :

- Conception "Break-away" (À décollement) permettant à l'amplificateur interne d'être retiré du logement et monté dans un emplacement caché
- REM1, Réglage du gain à distance (fonctionne seulement en mode des graves)
- HLA1, Adaptateur à niveau élevé tenant compte de la tension au niveau haut-parleur pour piloter l'amplificateur
- Fiches qui permettent de câbler d'abord le véhicule, puis de connecter l'amplificateur
- Filtres de sélection de fréquences passe-haut et passe-bas continûment variable
- Réglage d'amplification des basses fréquences (gain fixé)
- Lentilles de réglage interchangeables en plastique coloré (en option)
- Capacité de 2 ohms (sans chevauchement)
- Capacité d'entrée de 0.3-6.0Veff prévoyant une capacité de tensions de pilotage dans une gamme étendue provenant d'un récepteur ou d'un autre dispositif de média



ASSEMBLY & MOUNTING

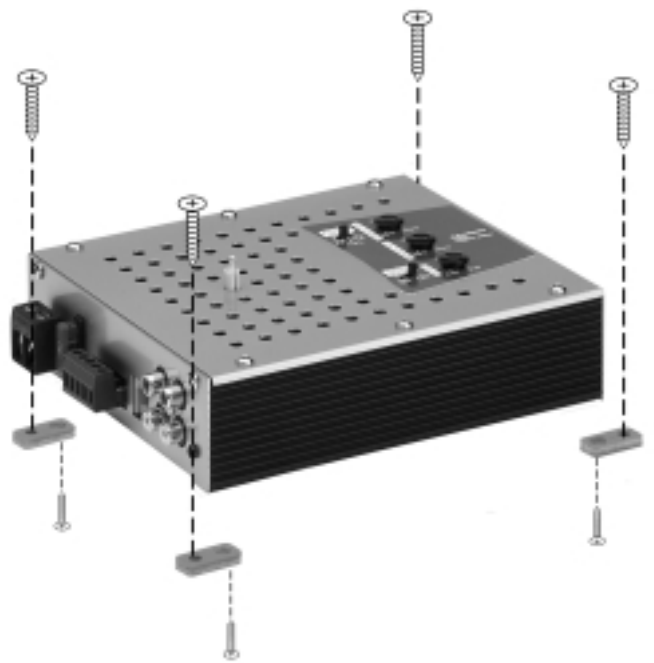
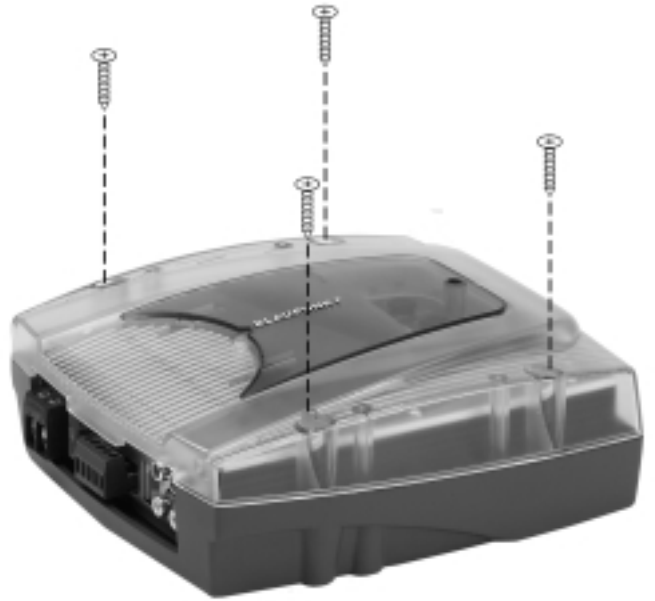
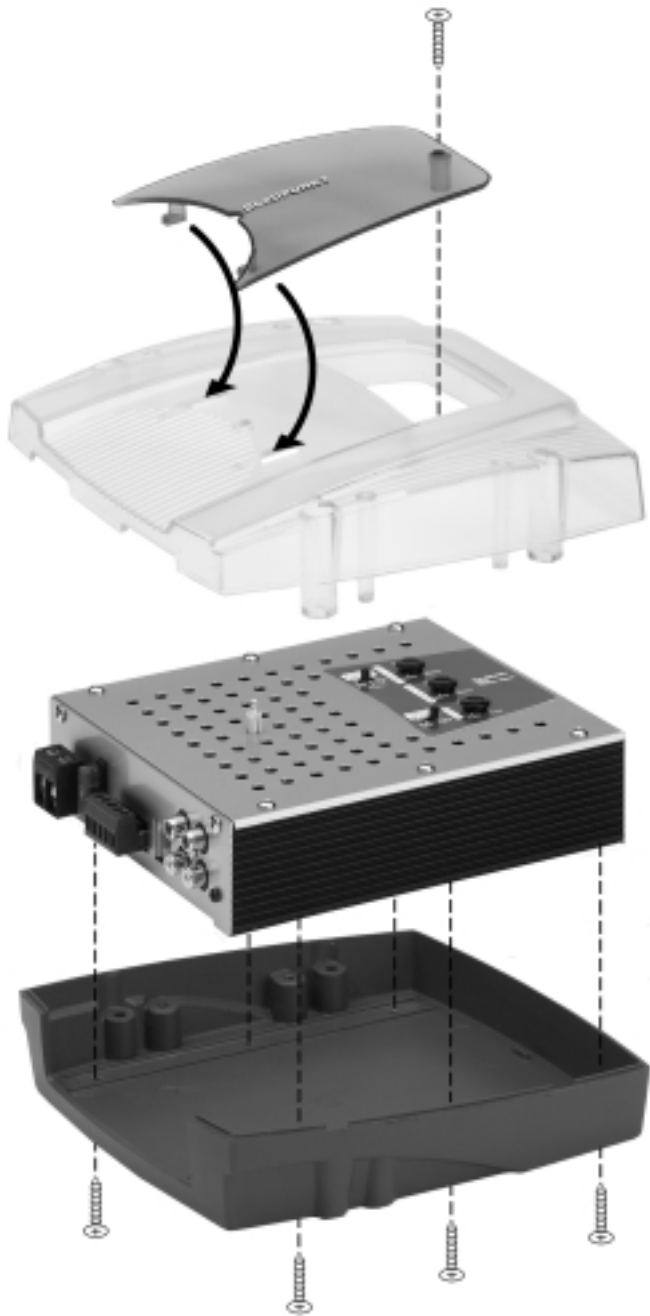

● BLAUPUNKT

Robert Bosch Corporation, Sales Group
Mobile Communications Division
2800 South 25th Avenue, Broadview, IL 60155
www.BlaupunktUSA.com

Copyright 2001 by the Robert Bosch Corporation
No portion of this work may be reproduced in any form without the written consent of the Robert Bosch Corporation
Tripath logo, name, and patents are protected by Tripath Corp, Santa Clara, CA

Printed in China (May, 2001)